

Product Specification

ML-3865-3526-B1H2 Bottom-port analog silicon microphone



● Description

ML-3865-3526-B1H2 is high performance bottom-port analog silicon microphone that receives the sound signal from the backside hole on PCB. By using our own innovative and unique MEMS silicon microphone chip design, MicroLink Senstech provides a series of packaged MEMS silicon microphones with compact size to achieve good performance such as high SNR, high sensitivity, excellent reliability and broad frequency response. This series of MEMS microphones find wide applications in cell phones, tablets, wearable devices and other portable electronic devices.

The ML-3865-3526-B1H2 has a sensitivity of -38dBV/Pa (tolerance of $\pm 1\text{dBV/Pa}$) with a signal-to-noise ratio of 65 dB, an extreme low total harmonic distortion of 0.1% at 94 dB SPL and very high acoustic overload point of 128 dB SPL.

● Features

- Gold coated metal housing package, immune to RF/EM interference.
- High mechanical strength, high temperature resistance and excellent reliability.
- Wide frequency response range, high sensitivity and pretty good signal-to-noise ratio.
- Withstand multiple times of SMT reflow process.

● **Applications**

Cell phones/smartphones, tablets, learning machines/game stations, MP3/DC/DV, computers/laptops, Bluetooth headsets/headphones, wearable smart systems, Iot related devices, etc.



● **Absolute maximum ratings**

Supply voltage: VDD to GND.....-0.3V~5V

ESD Tolerance

The Lid Mode.....8kV

The I/O Pin Mode4kV

Temperature Characteristics					
Parameter	Conditions	Min	Typ	Max	Unit
Operating Temperature		-40		+85	°C
Storage Temperature	Solder on PC board	-40		+105	°C
	In Tape and Reel	-10		+50	°C

● Acoustic and electrical specifications

Parameter	Symbol	Condition	Min.	Typ.	Max	Unit
Sensitivity	Sens	94dB SPL @1kHz	-39	-38	-37	dBV/Pa
Signal to Noise Ratio	SNR	20Hz to 20KHz, A-weighted	-	65	-	dB (A)
Output Impedance	Z _{out}	@ 1 kHz	-	-	200	Ω
Supply Voltage	V _{DD}		1.6	-	3.6	V
Current Consumption	I _{DD}		-	110	130	μA
Dimension			3.50×2.65×0.98			mm
Directivity			Omnidirectional			
Frequency Response	F		100~10k			Hz
Power Supply Rejection	PSR	217Hz, 0.1Vpp Square on VDD	-	-100	-	dBV (A)
Power Supply Rejection Ratio	PSRR	200mVpp sinewave @ 1 kHz	-	66	-	dB
Total Harmonic Distortion	THD	94 dB SPL @ 1kHz	-	0.1	-	%
		114 dB SPL @ 1kHz	-	0.5	-	%
Acoustic Overload Point	AOP	1% THD @ 1kHz	-	124	-	dB SPL
		10% THD @ 1kHz	-	128	-	dB SPL

● Frequency response

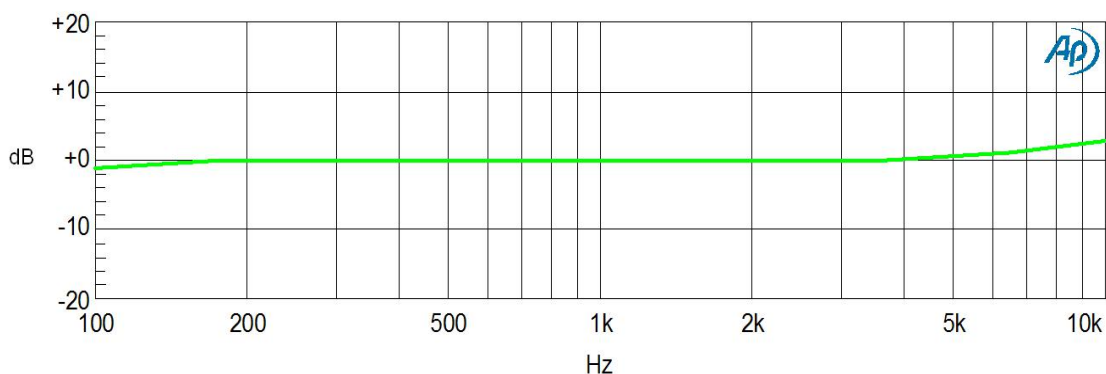
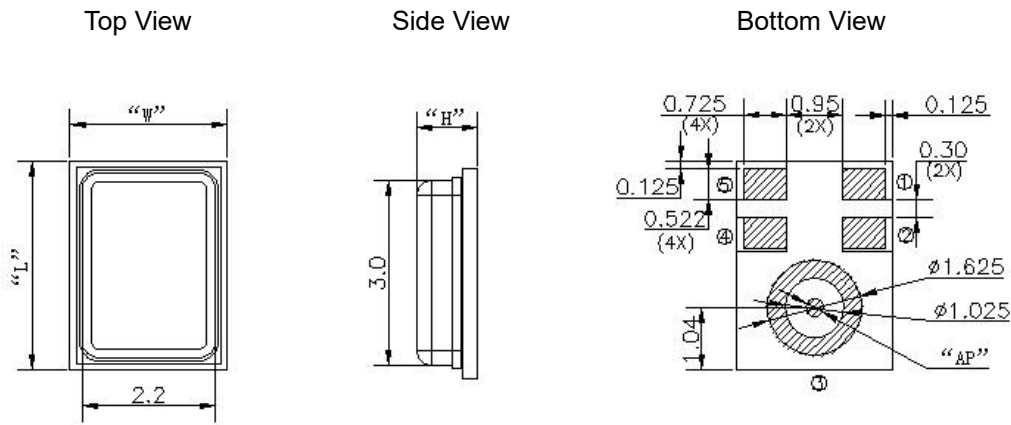

Figure 1. Typical free field frequency response (Normalized to 1 KHz)

● Mechanical specifications



Dimension		
Item	Dimension	Tolerance
Length(L)	3.50 mm	±0.1 mm
Width(W)	2.65 mm	±0.1 mm
Height(H)	0.98 mm	±0.1 mm
AP	φ0.325mm	±0.05mm

Pin #	Pin Name	Description
①	V _{OUT}	Signal output
②	GND	Ground
③	GND	Ground
④	GND	Ground
⑤	V _{DD}	Power

Figure 2. Detailed mechanical drawings

● Block diaphragm

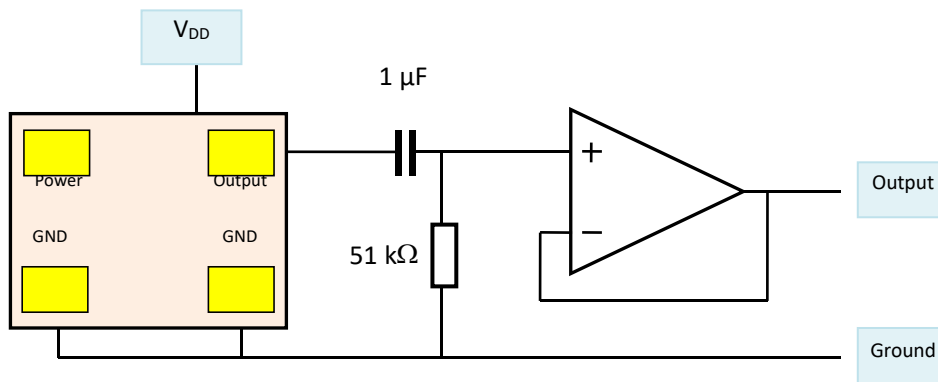

● Example Land Pattern

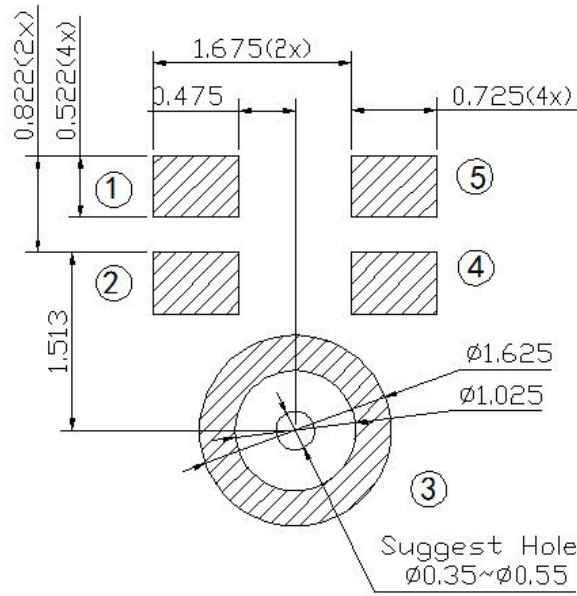
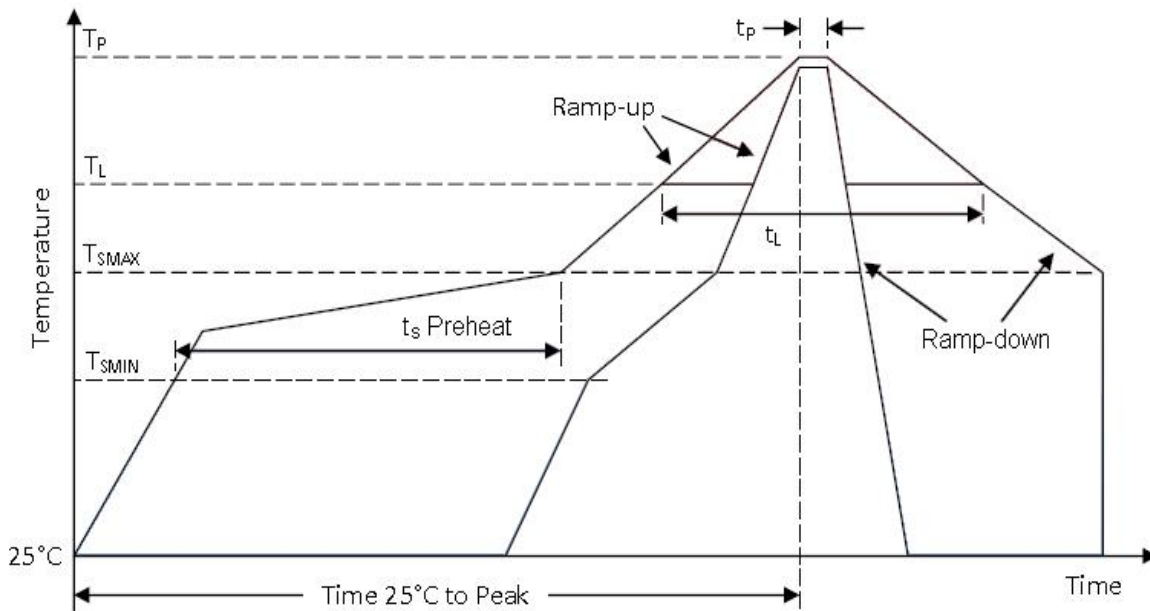

Figure 3. Recommended landing pattern on customers' PCB

● Recommended Reflow profile



Description		Parameter (lead-free)
Average temperature change rate ($T_{S_{MAX}}$ to T_p)		3 ⁰ C/second max.
Preheat	Minimum temperature ($T_{S_{MIN}}$)	150 ⁰ C
	Maximum temperature ($T_{S_{MAX}}$)	200 ⁰ C
	Time ($T_{S_{MIN}}$ to $T_{S_{MAX}}$) (t_s)	60-180 seconds
Reflow	Temperature (T_l)	217 ⁰ C
	Time (t_l)	60-150 seconds
Peak temperature	Temperature (T_p)	260 ⁰ C
	Time (t_p)	20-40 seconds
Cooling rate(T_p to $T_{S_{MAX}}$)		6 ⁰ C/second max
Time required from 25 ⁰ C to peak temperature		8 minutes max

Figure 4. Recommended leadless solder reflow temperature profile

Notes:

- 1) The air speed during reflow process should be low to avoid impurity entering the acoustic hole during reflow process.
- 2) Do not wash or clean the product to avoid impurity entering the product.
- 3) Do not carry out the reflow process more than 5 times. If the melting point of solders lower, the peak temperature should be accordingly reduced.

● Reliability Specifications

Test Item	Description
Temperature/Humidity Bias	168 hours at +85°C/85% R.H. under bias (JESD22-A101A-B)
Thermal shock	100 cycles air-to-air thermal shock from -40°C to +125°C with 15minute soaks. (IEC 68-2-4)
High Temperature Storage	168 hours at +105°C environment (IEC 68-2-2)
Low Temperature Storage	168 hours at -40°C environment (IEC 68-2-1)
Drop test	Using 150g fixture, 3 drops along each of 6 axes from 1.5m height onto slippery marble floor (IEC 68-2-27)
ESD-HBM	3 discharges of ± 2 kV direct contact to I/O pins. (MIL 883E, Method 3015.7)
ESD-HBM	3 discharges of ± 8 kV direct contact to lid while unit is grounded. (IEC 61000-4-2)
ESD-MM	3 discharges of ± 200 V direct contact to I/O pins. (ESD STM5.2)
Vibration test	4 cycles of 20 to 2,000 Hz sinusoidal sweep with 20 G peak acceleration lasting 12 minutes in X, Y, and Z directions (Mil-Std-883E, Method 2007.2 A)
Reflow test	5 reflow cycles with peak temperature of +260°C
Mechanical Shock	3 pulses of 10,000 G in the X, Y, and Z direction (IEC 68-2-27, Test Ea)

Notes: After reliability tests are performed, the sensitivity of the microphones shall not deviate more than 3 dB from its initial value. After 3 reflow cycles, the sensitivity of the microphone shall not deviate more than 3dB from its initial value.

● Packaging and marking detail

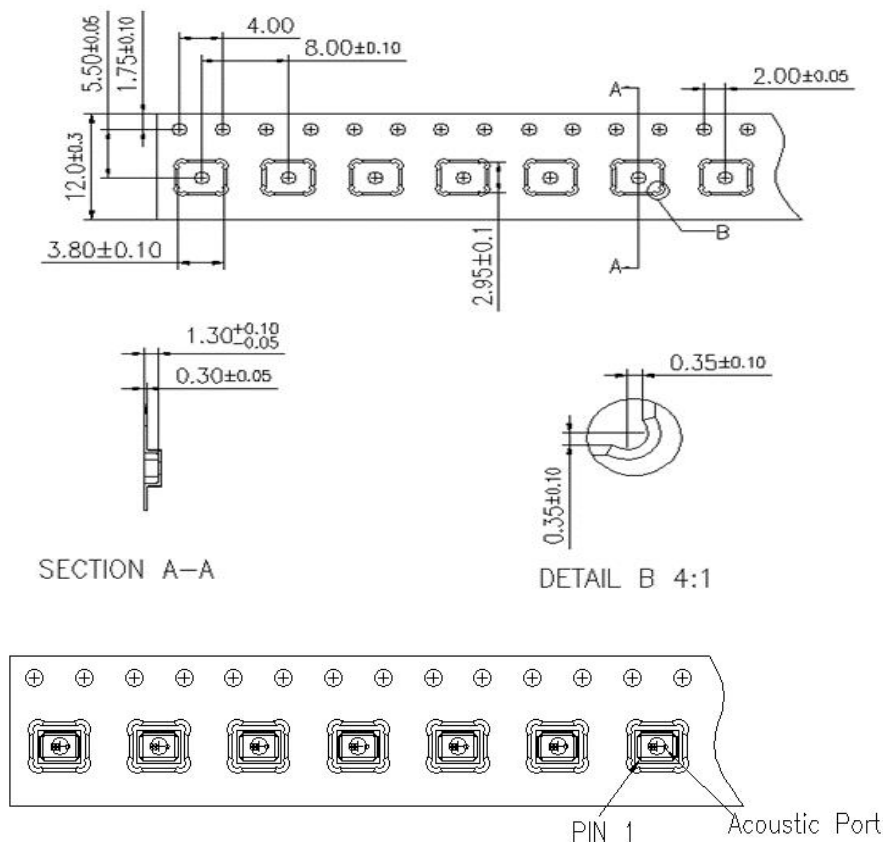

Model Number	Reel Diameter	Quantity Per Reel	Quantity Per Carton
ML-3865-3526-B1H2	13"	5,000	5,000 * 10 =50,000Pcs

Notes:

- 1) Dice are packaged in black carrier band which uses anti-electrostatic material. Each volume of packaged products is 5000 pcs.
- 2) The space between two dice is 8mm packaged in the carrier band with 12-mm width rolled in the reel of 13-inch diameter.
- 3) The first 50 pcs and the last 20 pcs are vacant.
- 4) The package requirements mentioned below is the company's standard delivery specifications. If you need special packages, please contact our sales staff.
- 5) All dimensions are in millimeters (mm) with tolerance of $\pm 0.3\text{mm}$.

● Materials Statement

- Meets the requirements of the European RoHS directive 2011/65/EC as amended.
- Meets the requirements of the industry standard IEC 61249-2-21:2003 for halogenated substances and SV SensTech Green Materials Standards Policy section on Halogen-Free.

● Remarks

- (A) MSL (moisture sensitivity level) Class 1.
- (B) Maximum of 3 reflow cycles is recommended.
- (C) In order to minimize device damage:
 - Do not board wash or clean after the reflow process.
 - Do not brush board with or without solvents after the reflow process.
 - Do not directly expose to ultrasonic processing, welding, or cleaning.
 - Do not insert any object in port hole of device at any time.
 - Do not apply over 30 psi of air pressure into the port hole.
 - Do not pull a vacuum over port hole of the microphone.
 - Do not apply a vacuum when repacking into sealed bags at a rate faster than 0.5 atm/sec.

● Version updates

Version	Updated Content	Updated Date
1.0	Initial release	2019-12-23
1.1	Update Current Logo change	2021-10-14

● Contact

SV SensTech Co., Ltd

Address: F2, No.200, Linghu Avenue, Wuxi, Jiangsu, Zip code 213135

Tel.: 86-510-85622282

Fax: 86-510-85622278

Email: sales@svsens.com

Website: www.svsens.com