

Product Specification

ML-2659-4030-DT1H3

Top-port Digital silicon microphone

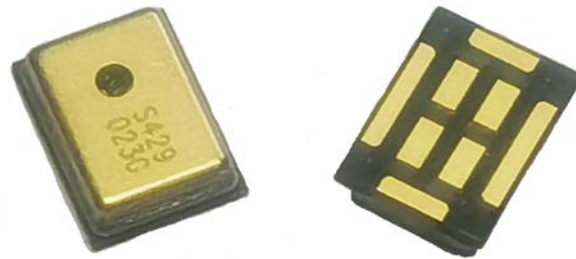

● Description

ML-2659-4030-DT1H3 is high-performance top-port digital silicon microphone that receives the sound signal from the hole on lid. By using our own innovative and unique MEMS silicon microphone chip design, MicroLink Senstech provides a series of packaged MEMS silicon microphones with compact size to achieve high performance such as high SNR, high sensitivity, excellent reliability and broad frequency response. This series of MEMS microphones find wide applications in smart speakers, cell phones, tablets, wearable devices and other portable electronic devices.

● Features

- Tiny size of 4.0×3.0×1.0 mm
- Sensitivity of -26dBFS (±1dBFS)
- High signal-to-noise ratio of 59 dB
- Extreme low THD of 0.1% at 94 dB SPL
- PDM Output
- High immune to RF/EM interference
- High mechanical strength
- High temperature resistance
- Excellent reliability

● Absolute maximum ratings

Parameter	Absolute Maximum Rating	Units
Vdd, DATA to Ground	-0.3, +5.0	V
CLOCK to Ground	-0.3, +5.0	V
SELECT to Ground	-0.3, +5.0	V
Input Current	±5	mA
Short Circuit to/from DATA	Indefinite to Ground or Vdd	sec
Temperature	-40 to +100	°C

Stresses exceeding these “Absolute maximum ratings” may cause permanent damage to the device. These are stress ratings only. Functional operation at these or any other conditions beyond those indicated under “Acoustic and electrical specifications” is not implied. Exposure beyond those indicated under “Acoustic and electrical specifications” for extended periods may affect device reliability.

● Acoustic and electrical specifications

TEST CONDITIONS: 23 ±2° C, 55±20% R.H., VDD=1.8 V, $f_{\text{clock}}=2.048$ MHz, SELECT pin grounded, no load, unless otherwise indicated

Parameter	Symbol	Condition	Min.	Typ.	Max	Unit
Supply voltage	Vdd		1.6		3.6	V
Sensitivity	Sens	94dB SPL @1kHz	-27	-26	-25	dBFS
Signal to noise ratio	SNR	94dB SPL @1kHz		59		dB (A)
Current consumption	I _{dd}	Vdd=1.8V, $f_{\text{clock}}=2.048$ MHz		650	850	μA
Sleep current	I _{SLEEP}	$f_{\text{clock}} \leq 1$ kHz		3	5	μA
Clock frequency range	f_{clock}		1.024		3.25	MHz
Clock Duty Cycle			40	50	60	%
Directivity			Omnidirectional			
Data format			1/2 Cycle 1-bit PDM			
Output load	C _{LOAD}				100	pF
Dimension			4.0×3.0×1.0			mm ³
Directivity			Omnidirectional			
Frequency response	F		100~10k			Hz
Power supply rejection	PSR	100mVpp square wave @ 217 Hz, A-weighted		-80		dBFS (A)
Total harmonic distortion	THD	94 dB SPL @ 1kHz		0.1		%
Acoustic Overload Point	AOP	10% THD @ 1 kHz		120		dB SPL

● Microphone interface specifications

Parameter	Symbol	Value			Unit
		Min	Type	Max	
Logic DATA high	V_{IOH}	$0.65 \times V_{dd}$		$V_{dd} + 0.3$	V
Logic DATA low	V_{IOL}	-0.3		$0.35 \times V_{dd}$	V
Clock duty cycle	$f_{\%}$	40		60	%

● Frequency response

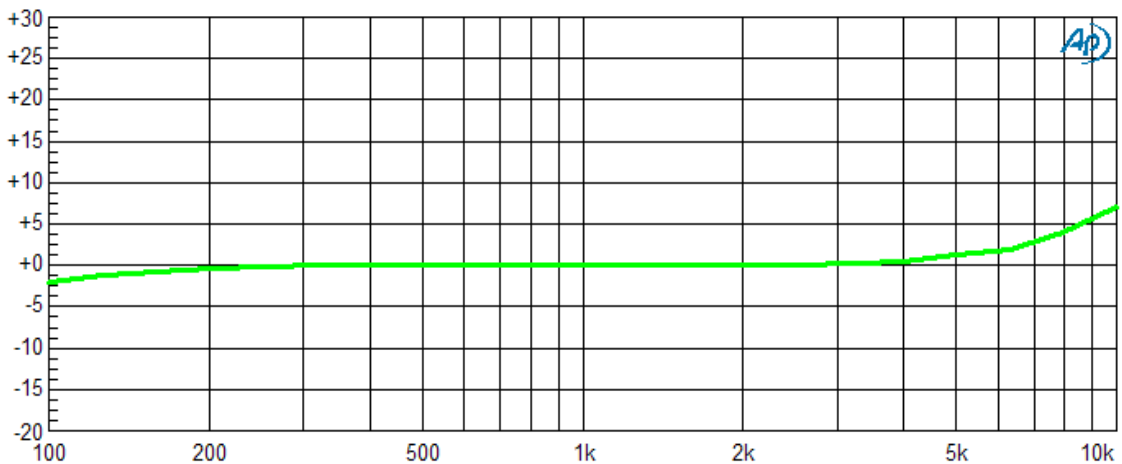

● Mechanical specifications

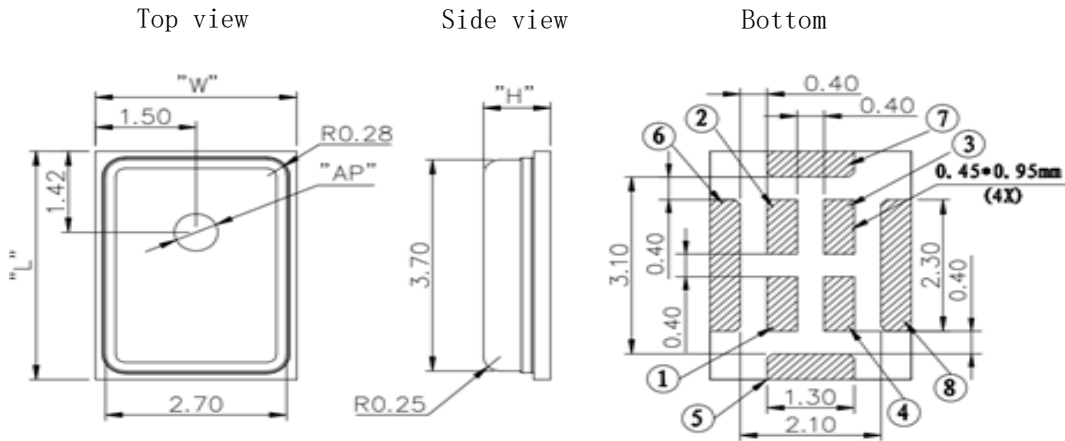

Item	Dimension	Tolerance	Units
Length(L)	4.0	±0.1	mm
Width(W)	3.0	±0.1	mm
Height(H)	1.0	±0.1	mm
AP	φ0.65	±0.05	mm

Pin #	Pin Name	Type	Description
①	VDD	Power	Power Supply
②	SELECT	Digital I	Lo/Hi (L/R) Select This pin is internally Pulled low
③	CLOCK	Digital I	Clock Input
④	DATA	Digital O	PDM Output
⑤, ⑥, ⑦, ⑧	GROUND	GROUND	Ground

● Interface circuit

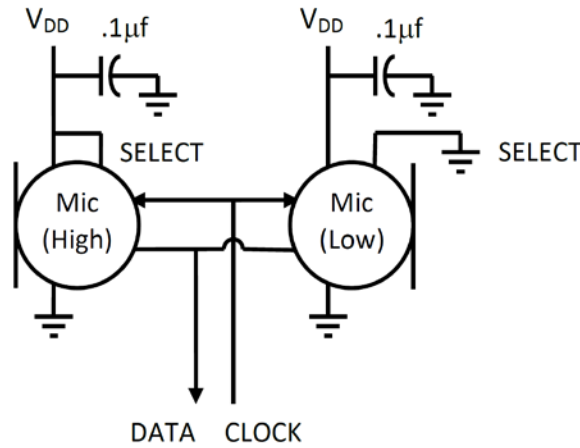

Microphone	SELECT	Asserts DATA On	Latch DATA On
Mic (High)	V _{DD}	Rising Clock Edge	Falling Clock Edge
Mic (Low)	GND	Falling Clock Edge	Rising Clock Edge

● Device state diagram

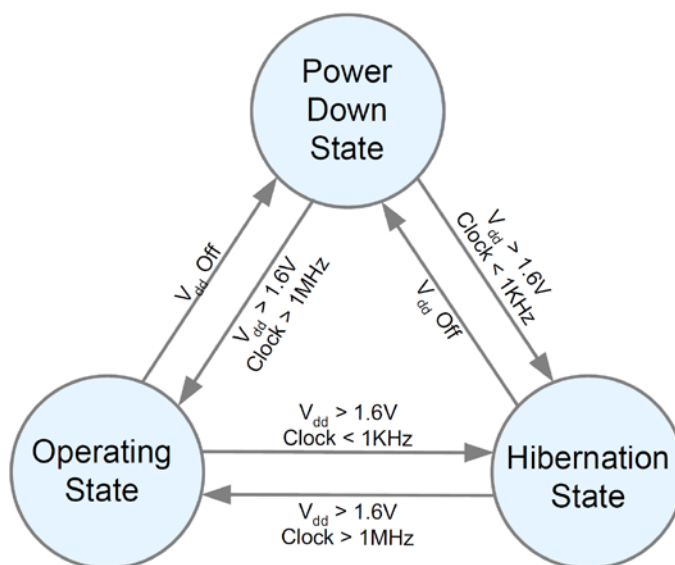

● Time diagram

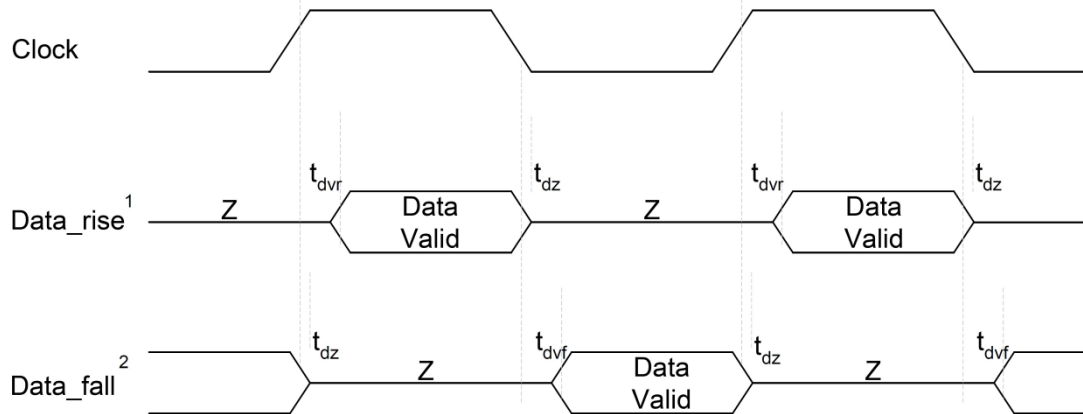

Note:

1. Data_rise : Data configured to be valid on the rising edge of the clock
2. Data_fall : Data configured to be valid on the falling edge of the clock

Parameter	Symbol	Min.	Typ.	Max	Conditions
Time required for data valid on the rising edge clock	t_{dvr}	18 ns		40 ns	$R_L = 1\text{ M}\Omega$, $C_L = 12\text{ pF}$
Time required for data valid on the falling edge clock	t_{dvf}	18 ns		40 ns	$R_L = 1\text{ M}\Omega$, $C_L = 12\text{ pF}$
Time required for data to be Z	t_{dz}	0 ns		15 ns	$R_L = 1\text{ M}\Omega$, $C_L = 12\text{ pF}$

● **Example Land Pattern**

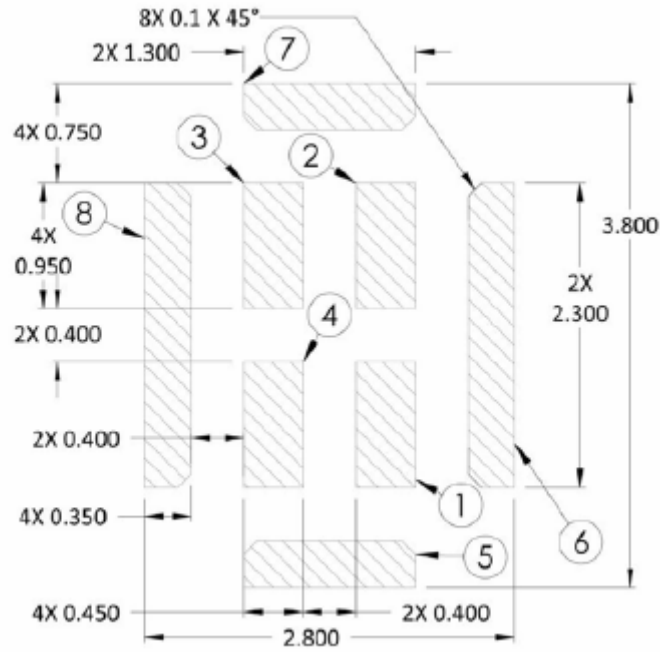

● **Reflow profile**

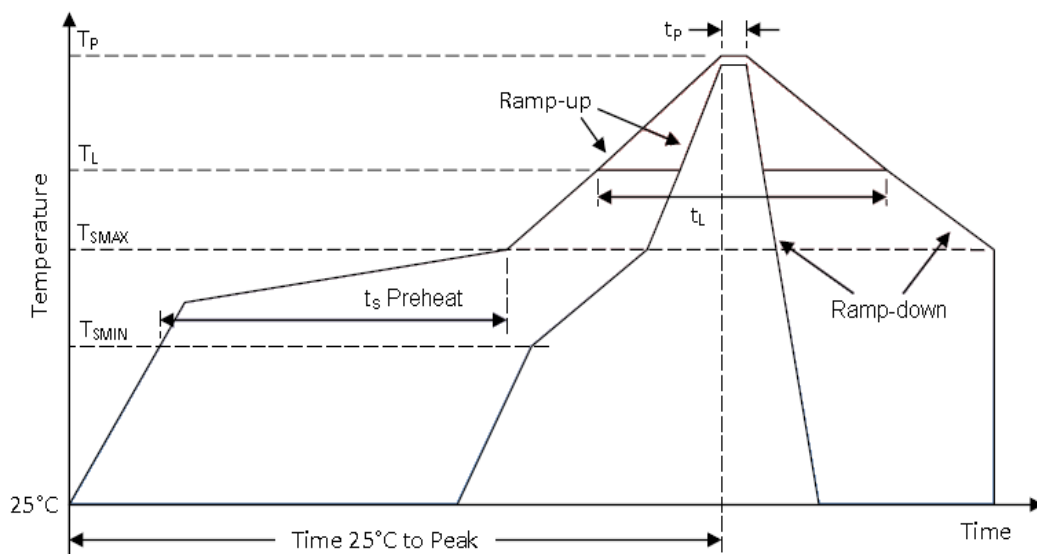

Recommended reflow profile limits

Description		Parameter (lead-free)
Average temperature change rate (T_{SMAX} to T_P)		3°C/second max.
Preheat	Minimum temperature (T_{SMIN})	150°C
	Maximum temperature (T_{SMAX})	200°C
	Time (T_{SMIN} to T_{SMAX}) (t_S)	60-180 seconds
Reflow	Temperature (T_L)	217°C
	Time (t_L)	60-150 seconds
Peak temperature	Temperature (T_P)	260°C
	Time (t_P)	20-40 seconds
Cooling rate (T_P to T_{SMAX})		6°C/second max
Time required from 25°C to peak temperature		8 minutes max

Notes:

- 1) The air speed during reflow process should be low to avoid impurity entering the acoustic hole during reflow process.
- 2) Do not wash or clean the product to avoid impurity entering the product.
- 3) Do not carry out the reflow process more than 5 times. If the melting point of solder is lower, the peak temperature should be accordingly reduced.

● Reliability index

Test Item	Description
Temperature/Humidity Bias	168 hours at +85°C/85% R.H. under bias(JESD22-A101A-B)
Thermal shock	100 cycles air-to-air thermal shock from -40°C to +125°C with 15minute soaks. (IEC 68-2-4)
High Temperature Storage	168 hours at +105°C environment(IEC 68-2-2)
Low Temperature Storage	168 hours at -40°C environment(IEC 68-2-1)
Drop test	Using 150g fixture, 3 drops along each of 6 axes from 1.5m height onto slippery marble floor(IEC 68-2-27)
ESD-HBM	3 discharges of ± 2 kV direct contact to I/O pins. (MIL 883E, Method 3015.7)
ESD-HBM	3 discharges of ± 8 kV direct contact to lid while unit is grounded. (IEC 61000-4-2)
ESD-MM	3 discharges of ± 200 V direct contact to I/O pins. (ESD STM5.2)
Vibration test	4 cycles of 20 to 2,000 Hz sinusoidal sweep with 20 G peak acceleration lasting 12 minutes in X, Y, and Z directions(Mil-Std-883E, Method 2007.2 A)
Reflow test	5 reflow cycles with peak temperature of +260°C
Mechanical Shock	3 pulses of 10,000 G in the X, Y, and Z direction(IEC 68-2-27, Test Ea)

Notes: After reliability tests are performed, the sensitivity of the microphones shall not deviate more than 3 dB from its initial value. After 3 reflow cycles, the sensitivity of the microphone shall not deviate more than 3dB from its initial value.

● Packaging and marking detail

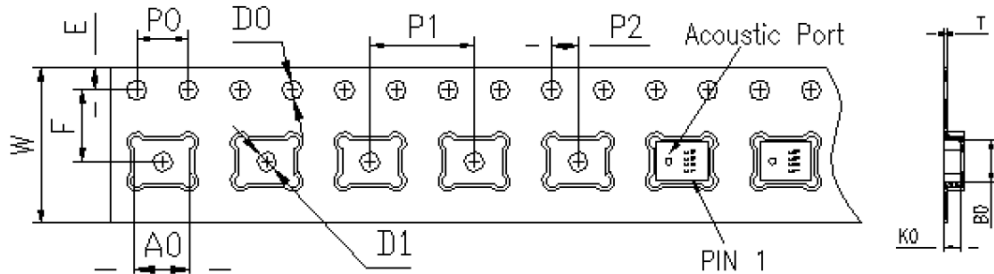

D0	1.5±0.1 mm	W	12.0±0.3 mm
D1	1.5±0.1 mm	E	1.75±0.1 mm
A0	4.2±0.1 mm	F	5.5±0.1 mm
B0	3.2±0.1 mm	P0	4.0±0.1 mm
K0	1.5±0.1 mm	P1	8.0±0.1 mm
T	0.3±0.05 mm	P2	2.0±0.1 mm

Model Number	Reel Diameter	Quantity Per Reel	Quantity Per Carton
ML-2659-4030-DT1H3	13"	5,000	5,000 * 10 =50,000Pcs

Notes:

- 1) Dice are packaged in black carrier band which uses anti-electrostatic material. Each volume of packaged products is 5000 pcs.
- 2) The space between two dice is 8mm packaged in the carrier band with 12-mm width rolled in the reel of 13-inch diameter.
- 3) The first 50 pcs and the last 20 pcs are vacant.
- 4) The package requirements mentioned below is the company's standard delivery specifications. If you need special packages, please contact our sales staff.
- 5) All dimensions are in millimeters (mm) with tolerance of ± 0.3mm.

● Materials Statement

- Meets the requirements of the European RoHS directive 2011/65/EC as amended.
- Meets the requirements of the industry standard IEC 61249-2-21:2003 for halogenated substances and SV SensTech Green Materials Standards Policy section on Halogen-Free.

● Remarks

- (A)MSL (moisture sensitivity level) Class 1.
- (B)Maximum of 3 reflow cycles is recommended.
- (C)In order to minimize device damage:
 - Do not board wash or clean after the reflow process.
 - Do not brush board with or without solvents after the reflow process.
 - Do not directly expose to ultrasonic processing, welding, or cleaning.
 - Do not insert any object in port hole of device at any time.
 - Do not apply over 30 psi of air pressure into the port hole.
 - Do not pull a vacuum over port hole of the microphone.
 - Do not apply a vacuum when repacking into sealed bags at a rate faster than 0.5 atm/sec.

● Version updates

Version	Updated Content	Updated Date
1.0	Initial release	2020-06-18
1.1	Update the packaging quantity per reel	2021-4-22

● Contact

SV SensTech Co., Ltd

Address: F2, No.200, Linghu Avenue, Wuxi, Jiangsu, Zip code 213135

Tel.: 86-510-85622282

Fax: 86-510-85622278

Email: sales@svsens.com

Website: www.svsens.com